

# CHARTER™ MAGNETIC WHITEBOARD

Model 2XMM

## Dual-Sided Dry Erase Whiteboard Full Panel

Divide your space and create distinct working zones with SMARTdesks® mobile magnetic dry erase boards. Easy to clean and built to last, these double-sided whiteboards are fabricated with durable porcelain and backed with steel. They are resistant to scratches, dents, staining, and ghosting while providing a convenient magnetic surface to post notes. A streamlined frame and the optionality of locking casters or feet create a sleek whiteboard that nests securely for ease of storage.

- Easy to move and divide your space into distinct working zones
- Framework is constructed using reinforced aluminum extrusion
- All metal parts are anodized, or powder coated for an aesthetic and durable finish
- Eurocast feet are reinforced and have 3" locking casters
- Nesting frame design allows for easy space-saving storage
- Easy to clean dry erase writing surface made from high-quality durable cured porcelain backed with magnetic steel
- Made in the USA



### Available in these dimensions:

- 37"W x 66"H
- 37"W x 76"H
- 49"W x 76"H

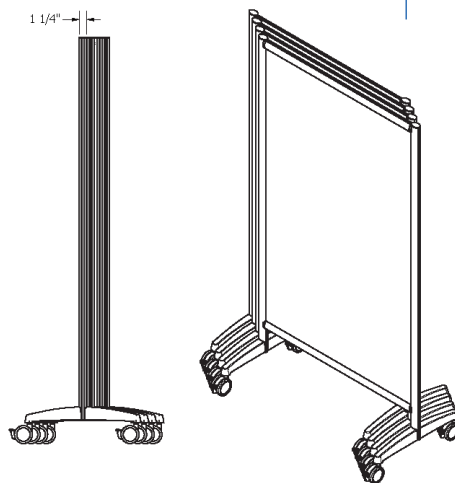
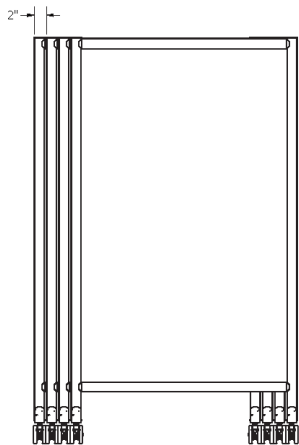

### Accessories Sold Separately

Flip Chart Clip Set  
(quantity 2)



FCC

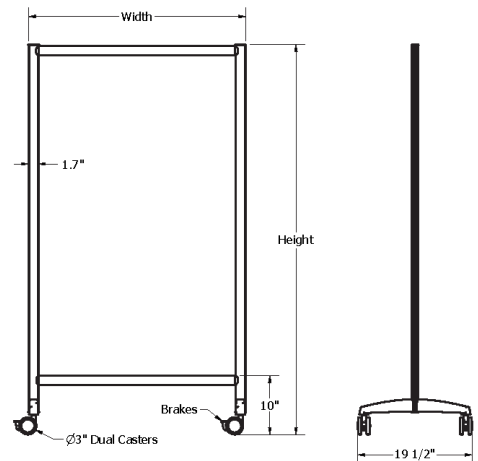

### FRAME COLOR



Silver Satin Aluminum  
AA



Black  
BK

800 770 7042 | [www.smartdesks.com](http://www.smartdesks.com)

**SMARTDESKS**®

where design meets technology<sup>sm</sup>