



Piatto™ Conference Table features diamond rift figured anigre veneer top with solid wood ebonized maple edge. We manufacture the tops of the ComDeck units to match the pattern.

ComDeck II Motorized

Each ComDeck unit provides 8 power receptacles and 4 configurable telecom plates. Each telecom plate mounts up to 4 connectors, specified online. ComDeck II operates with a switch located at the edge of the table, which actuates an electric motor to raise and lower the unit.

Specifications:

- All steel construction
- 4 duplex power receptacles, 15 amp, one on each side
- 6 ft. 14/3 SJT molded cord set with 15 amp plug
- Supplied with attractive brush trim, cut add mitered to accent table and facilitate installation access
- 4 locations for telecom plates that are purchased separately

Dimensions:

- Lift: 3 inches
- Mounting flange: 14.5 inches square
- Depth: 7 inches
- Depth with optional outer pan: 10.675 inches
- Outer pan mounting flange: 17 inches square

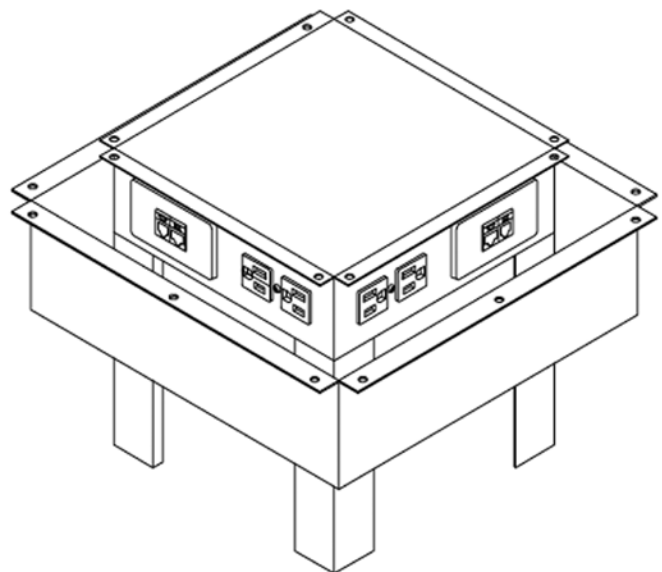

www.smartdesks.com
800 770 7042

ComDeck

Table Preparation

Step 1. Decide exactly where you would like the ComDeck on the table.

Step 2. CUTTING THE TABLE (The following Instructions are specified for the installation of the supplied brushes)

Option 1: Hand Cutting

On the underside of the table place the template (consult factory for template) where the ComDeck will be positioned. If the table is elongated, position the elongated template along the same axis.

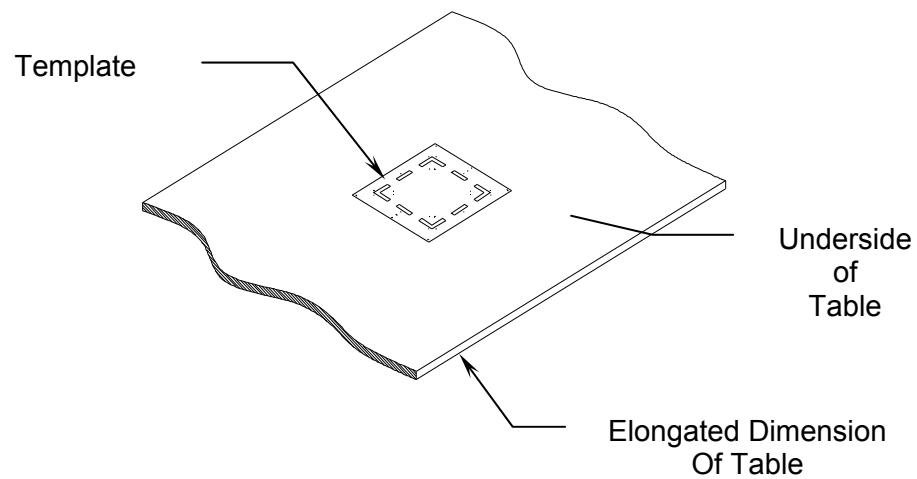

Tack the template in place. Mark the 26 pilot-hole locations as shown. Scribe marks for the 2 cutout squares.

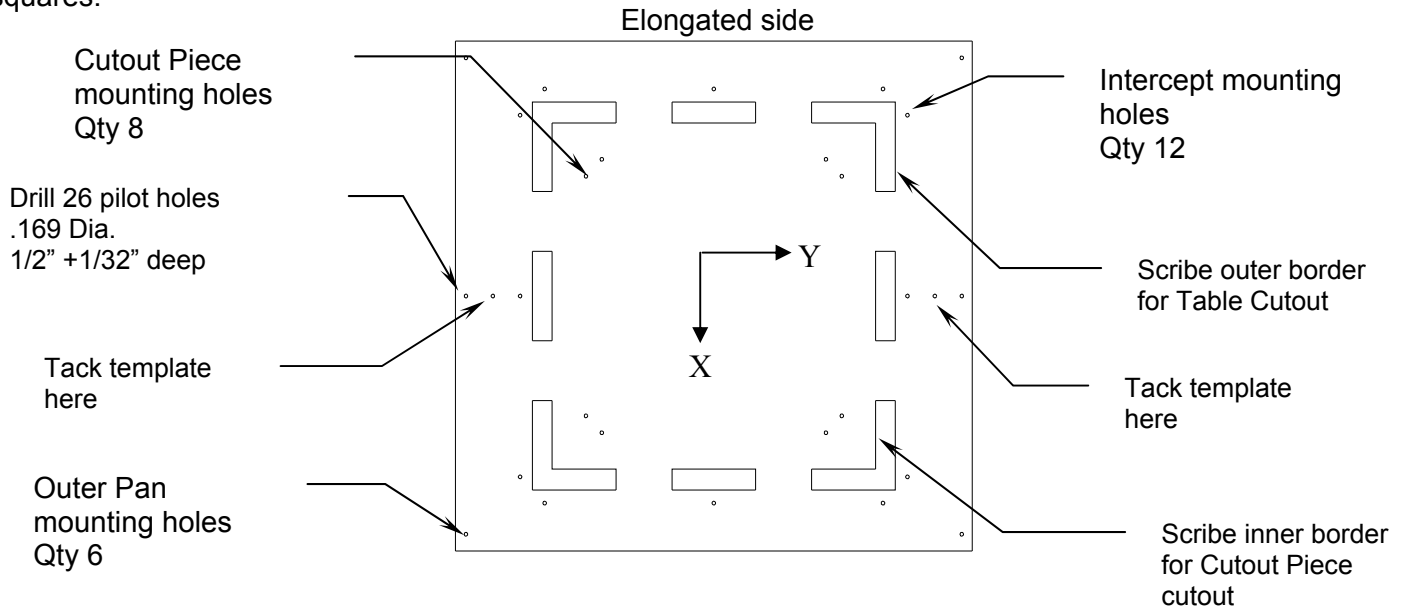

Remove the template and join scribe marks to create inner and outer squares. Drill 26 pilot holes using a #18 drill (.1695 dia), use caution to prevent drilling through table surface.

Cutout *and retain* inner square (11-5/8" x 11-5/8"). This will be called CUTOUT PIECE. The CUTOUT PIECE will be mounted to the MAIN HOUSING during ComDeck installation. NOTE: see step 4.

Note: Mark the direction of the CUTOUT PIECE prior to removal, this will ensure that the grain or pattern will match the table after installation.

Cutout the outer square (13-1/8" x 13-1/8"). Make certain that there are sharp corners on this square hole.

Option 2: CNC Cutting

Use the following coordinates for CNC machining (note: coordinates are from center of ComDeck). (X , Y)

Cutout Piece Mounting Holes:
Holes (optional):

-4.02 , 4.59
4.02 , 4.59
4.59 , 4.02
4.59 , -4.02
4.02 , -4.59
-4.02 , -4.59
-4.59 , -4.02
-4.59 , 4.02

Intercept Mounting Holes:

-6.00 , 6.95
0 , 6.95
6.00 , 6.95
6.95 , 6.00
6.95 , 0
6.95 , -6.00
6.00 , -6.95
0 , -6.95
-6.00 , -6.95

Outer Pan Mounting

-8.00 , 8.90
0 , 8.90
8.00 , 8.90
8.00 , -8.90
0 , -8.90
-8.00 , -8.90

Cutout Piece (11.625 square):

-5.81 , 5.81
5.81 , 5.81
5.81 , -5.81
-5.81 , -5.81

Table Cutout (13.125 square):

-6.56 , 6.56
6.56 , 6.56
6.56 , -6.56
-6.56 , -6.56

Note: If laminate is to be used to finish this opening adjust the cutout to accommodate its thickness. The finish opening should measure 13-1/8" x 13-1/8".

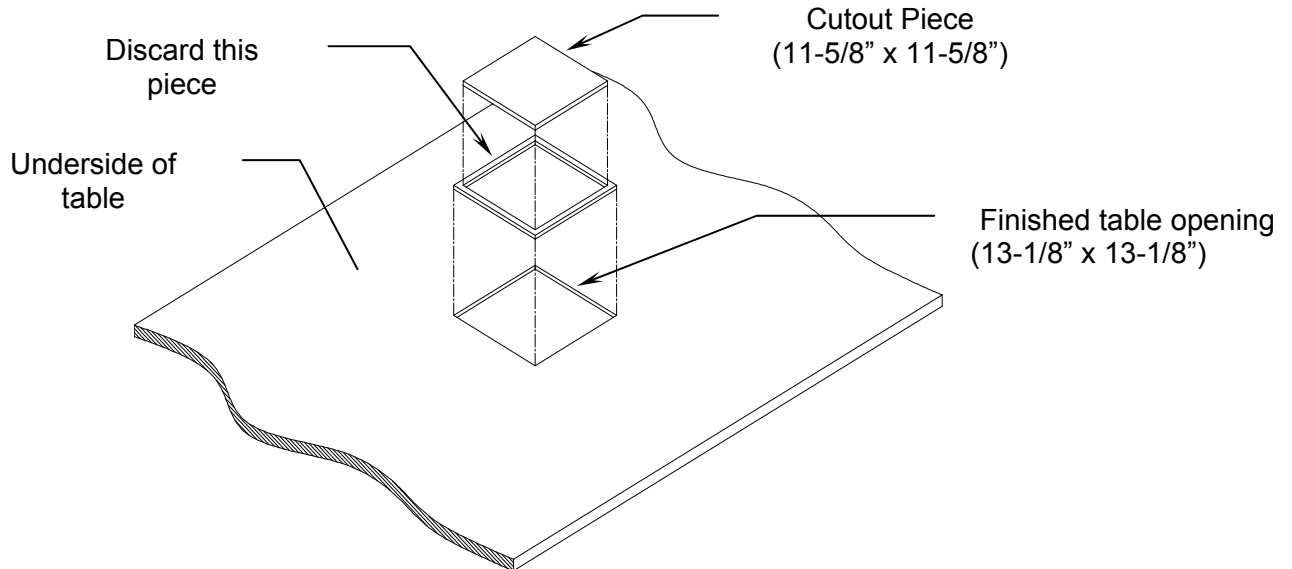

Finish off the outside edges on the CUTOUT PIECE and the inside edges on the table's square hole. Either laminate or apply a waterproof finish.

Step 3. Install 4 TABLE BRUSHES to the inner sides of the table's square cutout. Install each TABLE BRUSH with 3 #4 screws (supplied).

Note: Make certain the top edges of the TABLE BRUSHES are flush with the top surface of the table.

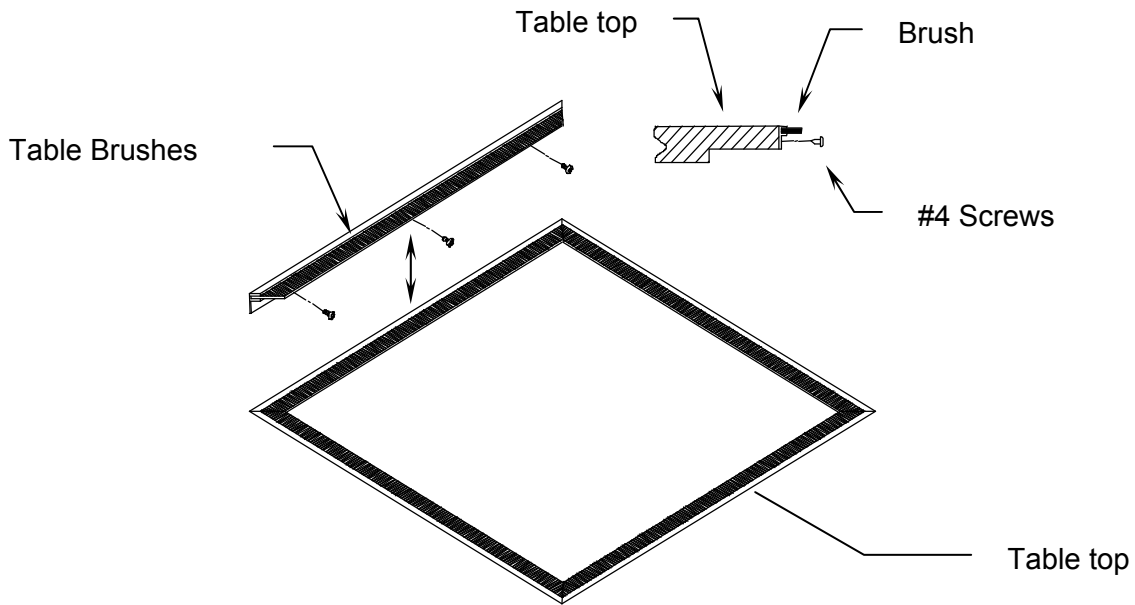

Step 4. Determining CUTOUT PIECE Thickness.

The Intercept has inner pan mounting flanges with four position holes in them that permit the installer to mount the flanges at a position that best suits the table thickness their working with.

Position 1	Table Thickness Between	.656 - .83	Shipping Position
Position 2	Table Thickness Between	.83 - 1.125	
Position 3	Table Thickness Between	1.125 - 1.375	
Position 4	Table Thickness Between	1.375 – 1.625	

This feature means that the CUTOUT PIECE is not a fixed thickness any longer. Below is a chart that lists the position of the top of the housing in relationship to the Inner Pan mounting flanges for each position.

Position 1	Housing Flush with Flanges
Position 2	Housing .34 Higher Than Flanges
Position 3	Housing .59 Higher Than Flanges
Position 4	Housing .84 Higher Than Flanges

The installer needs to subtract the number from the chart above, based on their mounting position, from their actual table thickness and this will be the thickness the Cutout Piece needs to be.

Example: If the actual table thickness is 1-1/16" (1.0625) that means the flanges should be set at position 2. In position 2 the housing sticks up above the flanges by .34. So subtract .34 from 1.0625 and the Cutout Piece thickness should be .72 or 23/32" of an inch. (the customer can modify always change from these recommendations)

Step 5. Install ComDeck using next section of instructions.

ComDeck 2 Installation

NOTE: DO NOT ATTEMPT TO INSTALL THE ComDeck PRIOR TO READING THESE INSTRUCTIONS

- Step 1.** Prepare table per instructions on separate sheet. Be sure to retain portion of cut out tabletop if it will become the finished top of the ComDeck 2.
- Step 2.** Unpack the ComDeck 2, being careful not to damage any part, and check to ensure that no items were damaged during shipping. Review parts list to be sure all parts are present.
- Step 3.** TABLE THICKNESS ADJUSTMENT - The INNER PAN ASSY has four (4) adjustable mounting flanges that can be set for your specific table thickness between .656" - 1.625". The flanges come set for the thinnest table. To change the flanges remove the lock nuts (2 per flange) and move the flanges to the hole that corresponds with the table thickness that the ComDeck 2 will be mounted in.

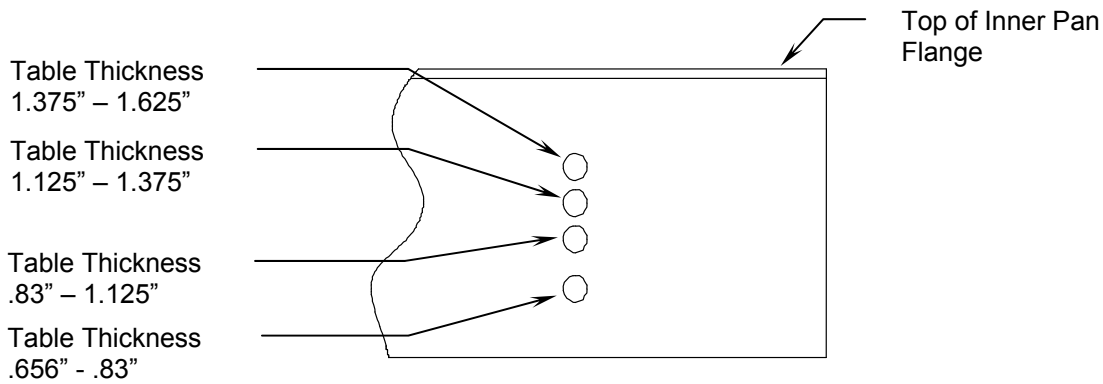

Tighten the lock nuts; be sure all of the flange tops are at the same height

- Step 4.** TABLE CUTOUT MOUNTING - Attach CUTOUT PIECE, from table preparation, to top of MAIN HOUSING. The 8 pilot holes should line up. From underside of the INNER PAN, insert screws (use magnetic screwdriver) and secure the CUTOUT PIECE to the MAIN HOUSING.

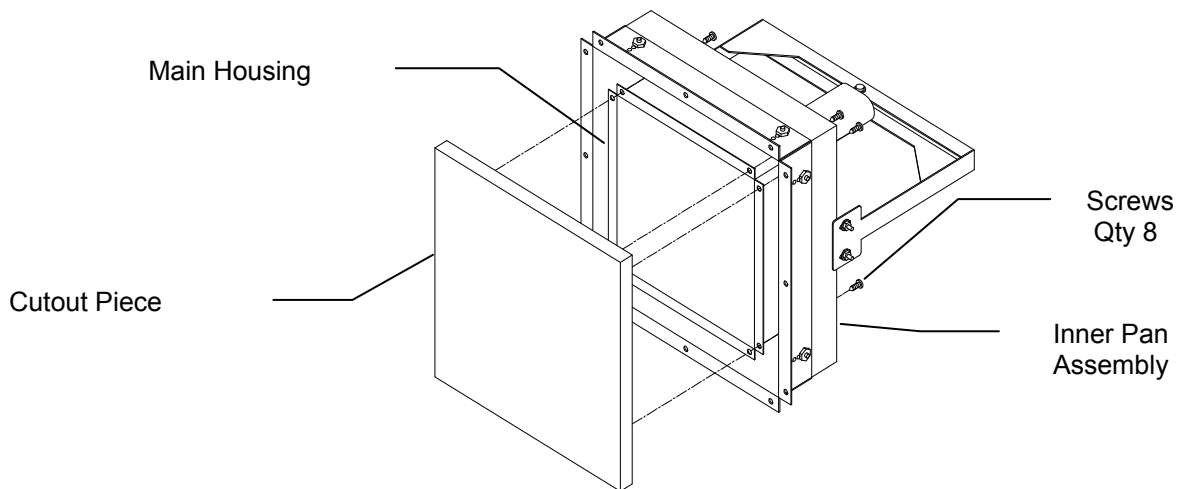

Step 5. INNER PAN MOUNTING - Place the INNER PAN ASSY. to the underside of the table and secure with twelve (12) #10 X ½ screws provided, use pilot holes to ensure proper alignment. **NOTE:** USE CAUTION WHEN POSITIONING THE ComDeck 2 ON THE TABLE, ENSURE THAT THE GRAIN OF THE CUTOUT PIECE MATCHES THE TABLE.

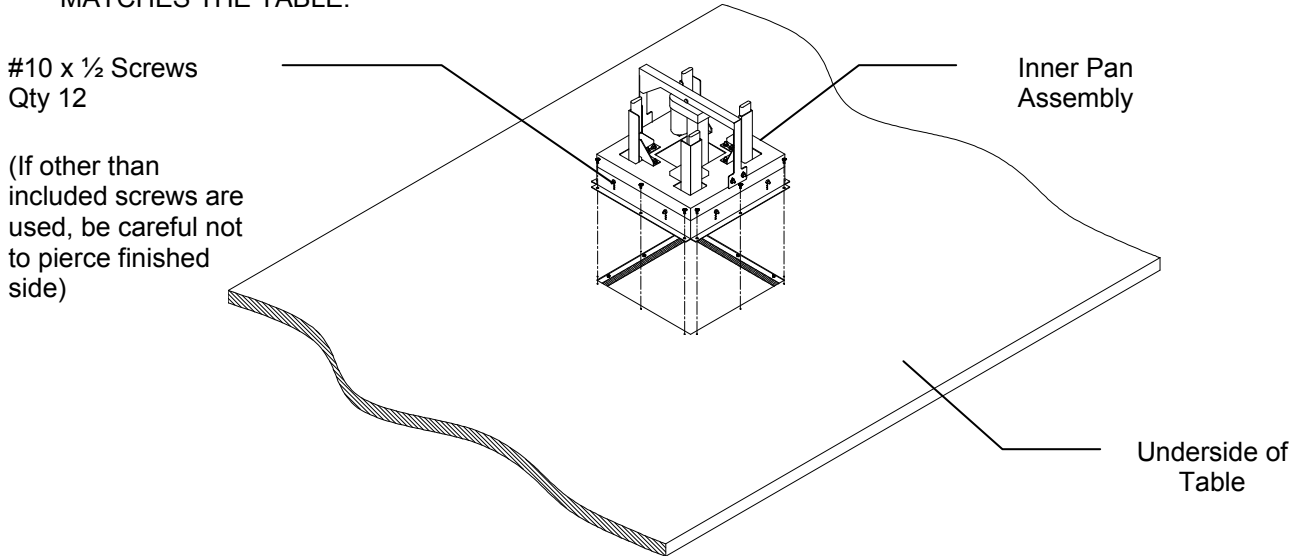

Step 6. OUTER PAN MOUNTING - Position the OUTER PAN ASSY. below the mounted INNER PAN ASSY. Connect the power feed (Twist-Lock), and motor feed wires (RED and BLACK) from the OUTER PAN ASSY to the MAIN HOUSING Twist-Lock and motor. Be sure to feed the wire through the cutout in the OUTER PAN. Attach the OUTER PAN ASSY to the underside of table with six (6) #10 X ½ screws provided. Use pilot holes to ensure proper alignment.

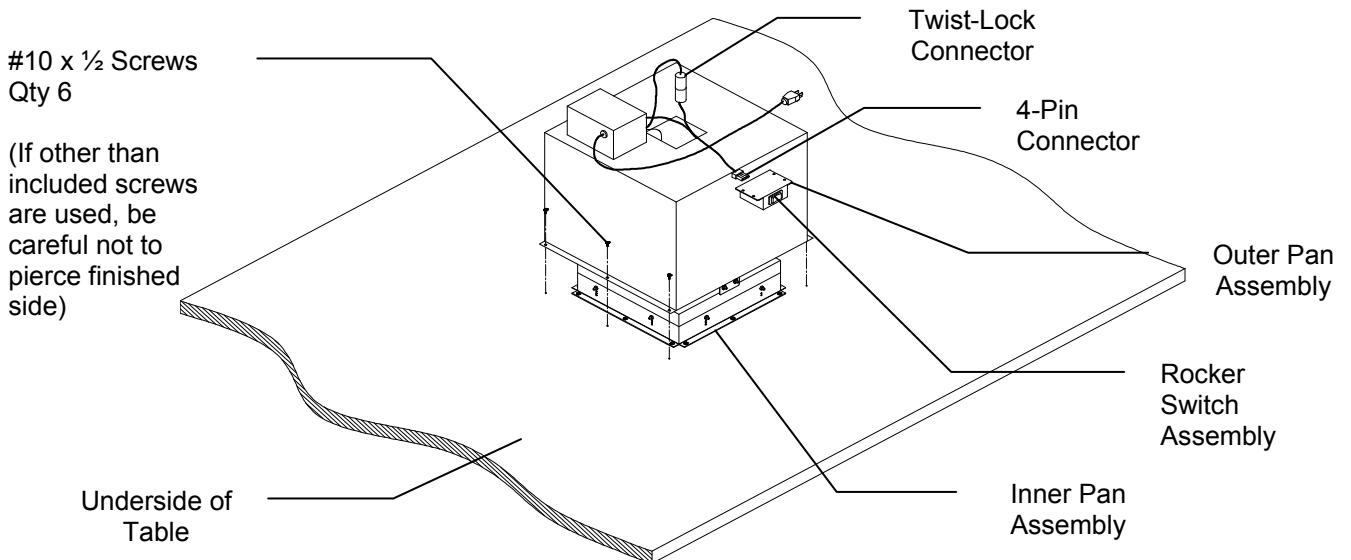

Step 7. Plug the ROCKER SWITCH ASSY onto the cable utilizing the 4-pin connector, plug in the unit and test for proper operation. By pressing the “Raise” side of the ROCKER SWITCH the ComDeck 2 should elevate and lock at top. By pressing the “Lower” side of the ROCKER SWITCH the ComDeck 2 should return to the original, retracted, position.

If ComDeck 2 doesn't operate, check:

1. ComDeck 2 is plugged into a powered outlet.
2. Twist-Lock connector between Power Unit and MAIN HOUSING is completely locked into place by twisting.
3. Motor connector is completely latched.

Step 8. ROCKER SWITCH MOUNTING – Mount the ROCKER SWITCH ASSY. in a convenient location using #10 x ½ screws provided. Secure wire as needed.

Step 9. VOICE/DATA CONNECTIONS - Raise the ComDeck 2, remove the 4 VOICE/DATA Plates, using the special tool provided, and snake the VOICE/DATA wires up through the OUTER PAN and through the 2 SHUTTER BUSHINGS in the bottom of the MAIN HOUSING. Wires should be dressed to move freely up and down with the movement of the MAIN HOUSING. This step can be done before mounting the ComDeck 2 however, be sure all wires are run through the cutout in the OUTER PAN before completing step 5.

Congratulations. Enjoy your ComDeck 2.

PARTS LIST

Inner Pan Assembly	Qty 1
Outer Pan Assembly	Qty 1
Rocker Switch Assembly	Qty 1
Table Brush	Qty 4
7/64 Allen Wrench	Qty 1
#10 X ½ Pan Head Screw	Qty 20
#4 X ½ Pan Head Screw	Qty 12
Table Preparation Instructions	Qty 1
Installation Instructions	Qty 1
Housing Adjustment Instructions	Qty 1

ComDeck Adjustment Sheet

The ComDeck unit offers an adjustment of both height and alignment of the final position of the CUTOUT PIECE, in relationship to the tabletop, after installation.

Height Adjustment

1. The CUTOUT PIECE can be moved up and down, slightly, by loosening the Height Adjustment Screws.
Note: To raise or lower one corner the adjustment screws on adjacent corners needs to be loosened also.
2. Adjust CUTOUT PIECE as needed and tighten all Height Adjustment Screws.

Height Adjustment
Screws
Qty 8

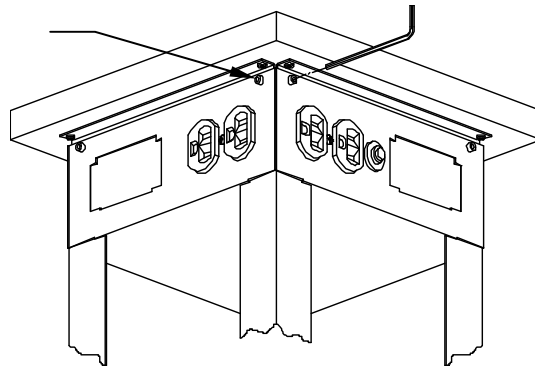

Alignment Adjustment

1. The CUTOUT PIECE can be moved, slightly, front to back and side to side by loosening the twelve (12) Adjustment Screws at the bottom of the Inner Pan and moving the Inner Pan Base as needed.
2. After the CUTOUT PIECE is moved to the proper position, tighten the twelve (12) Adjustment Screws.

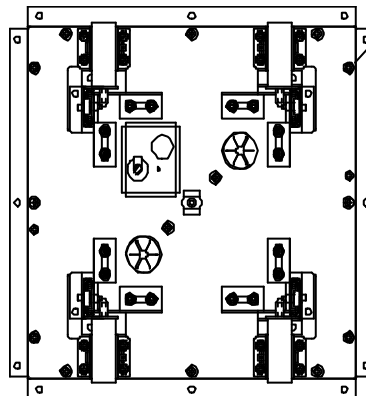

Adjustment Screw
Qty 12