

OASIS™ & OASIS™ MINI INSTALLATION

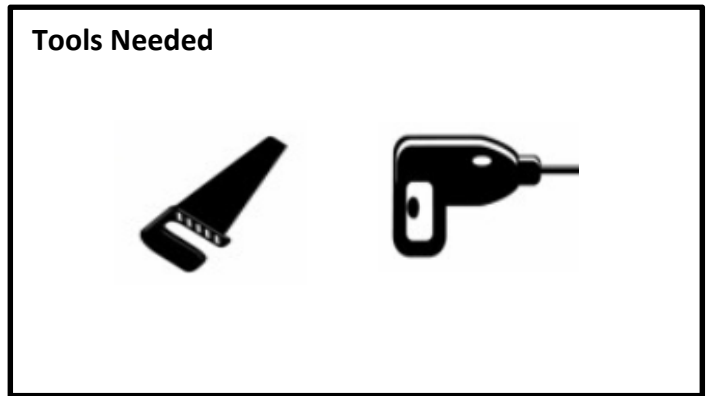
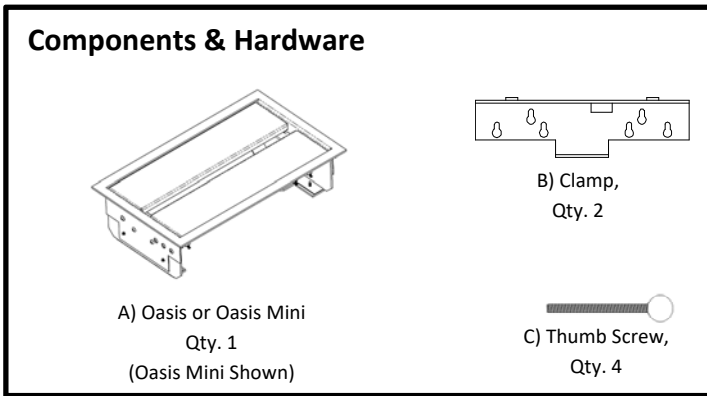

For use with: This product fits tables .88" – 2" thick.

CUTOUT SIZES

	Oasis	Oasis Mini
Cutout Width	8.25"	8.25"
Cutout Length*	29.12"	14.12"

*Undercut required along this length

1- Locate and cut the hole for the Oasis or Oasis Mini based on the chart to the right (.125" max corner radii). Note undercut required for lid clearance along both long sides (see Detail A & C). Insert the Oasis or Oasis Mini (A) into the cutout from above.

2- Key slots in clamps (B) engage over T-studs on Oasis's (A) side plates, and thumb screws (C) thread into clamps and tighten against the underside of the table. Use outermost key slots on clamps for Oasis & Oasis Mini (see detail B & C). Note: inner key slots on clamp (B) are not used for this product.

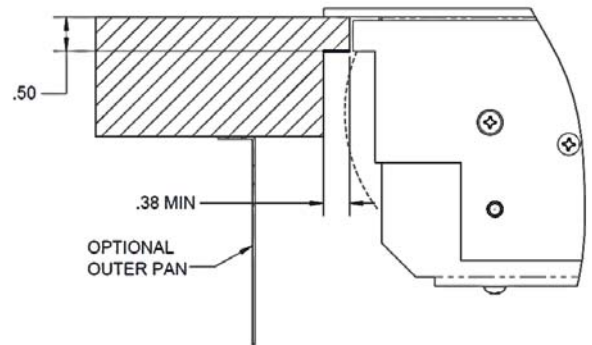

Detail A

3- Connect all power and data cabling as needed.

4- Check lids for smooth and uninterrupted movement.

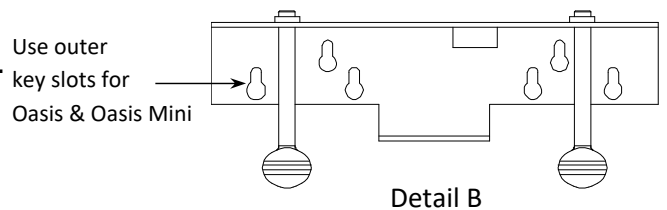

OASIS™ & OASIS™ MINI INSTALLATION

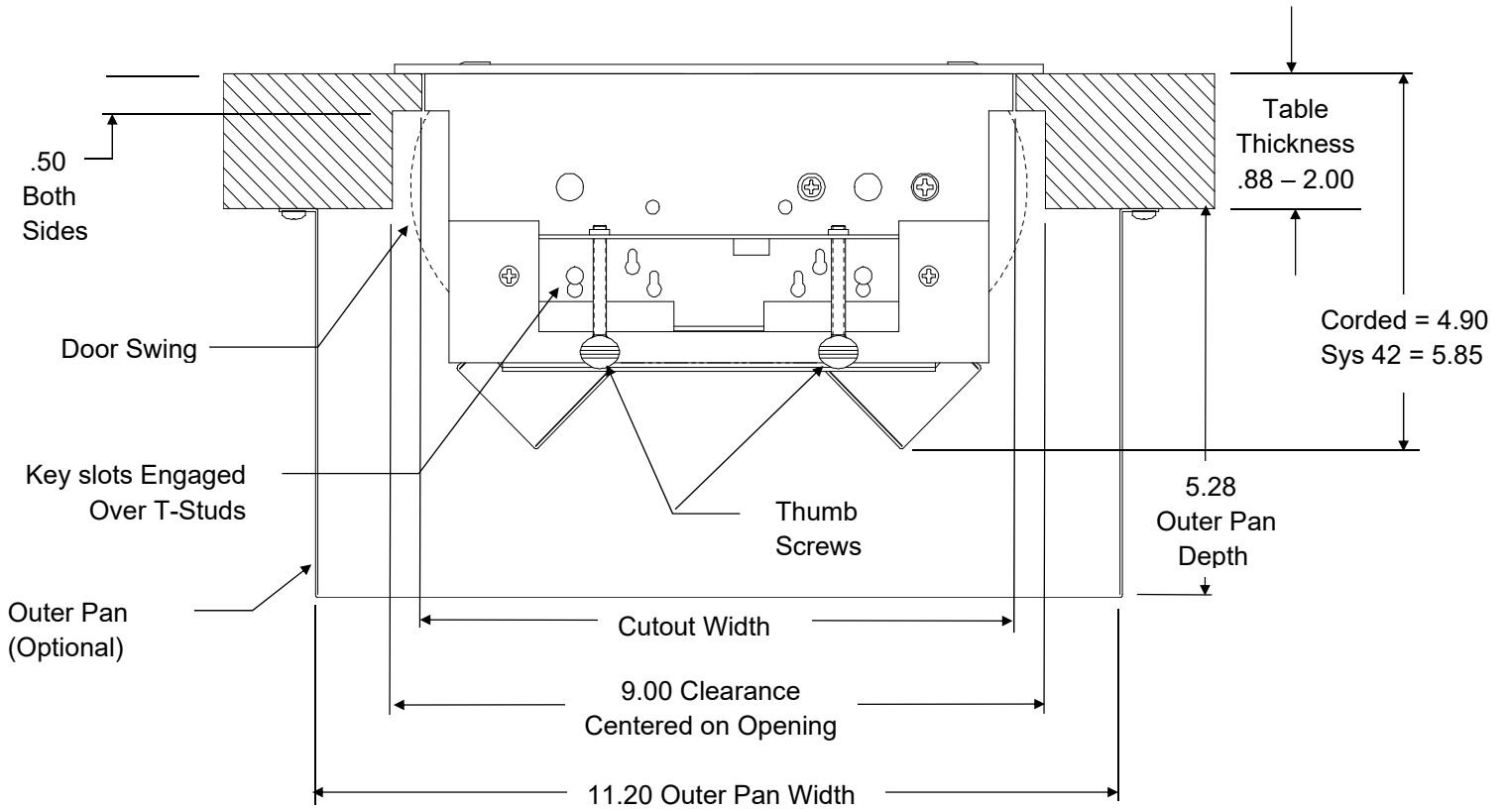

Detail C